

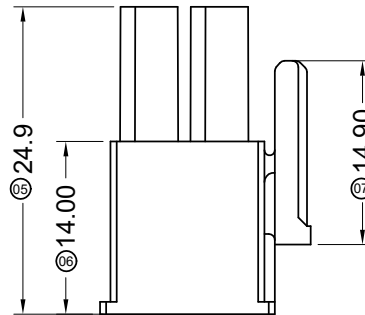

RoHS

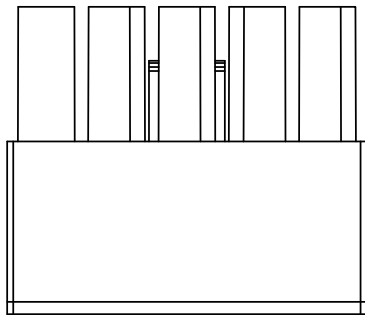
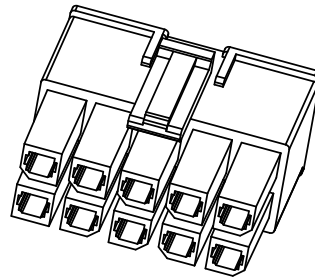
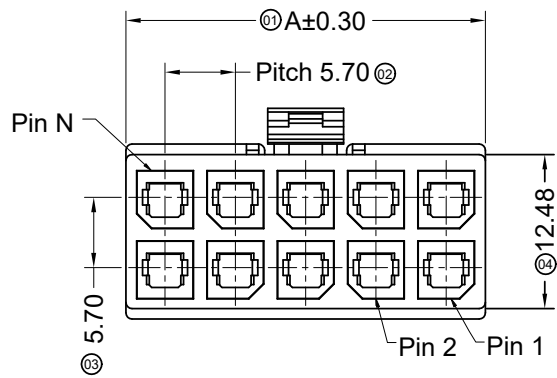

■ Specifications :

- Voltage rating: 600V AC / DC
- Current rating: 23A AC / DC
- Withstanding voltage: 2200V AC/minute
- Temperature range: -40°C~+105°C
- Insulation resistance: ≥1000MΩ
- Contact resistance: ≤2mΩ
- After environmental testing: ≤10mΩ
- Suitable GYA Terminal: 5700T Mates
- With GYA Wafer: 5700W

5700 H X-2\*XX X-N0 BK

① ② ③ ④ ⑤ ⑥ ⑦

① Series No.

② Category: H-HSG

③ Welding Board Angle:

④ Row No.-Pin No.: 2\*XX-2\*01P~2\*06P

⑤ Plug the Pin & special No.:

⑥ Material: N0-PA66 94V-0

⑦ Color: Bk-Black

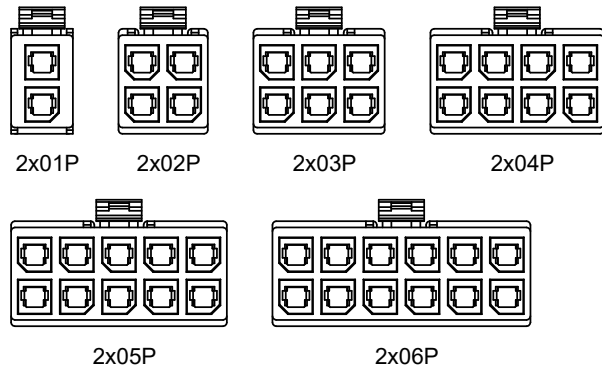

Poles	Dimensions (mm)
	A
2*01	8.35
2*02	12.05
2*03	17.75
2*04	23.45
2*05	29.15
2*06	34.85

					GENERAL TOLERANCE		<b>东莞市国亚电子有限公司</b> DONGGUO GUOYA ELECTRONICS CO.,LTD				PART NO.					
					.X ±0.30						5700HX-2*XX-N0BK					
					.XX ±0.20						TITLE					
					.XXX ±0.10						5.70 mm Crimp Style Connectors					
					X.° ±2°						APPROVAL		CHECK	DRAWN	DATE	UNIT
DATE	REV	ECN NO	DESCRIPTION	MODIFY	APPROVAL	PROJECT	YANG	TIAN	TIAN	2017/09/08	mm	1:1	1/1	A0	A-000	

RoHS

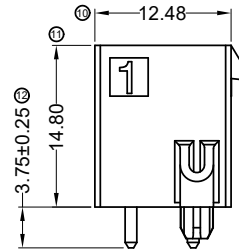
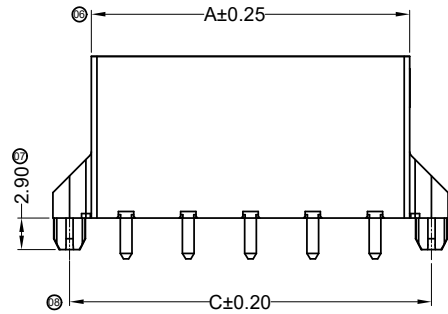
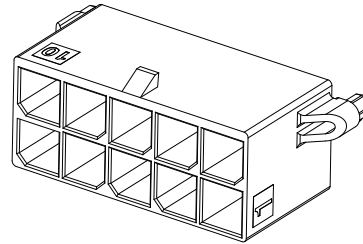
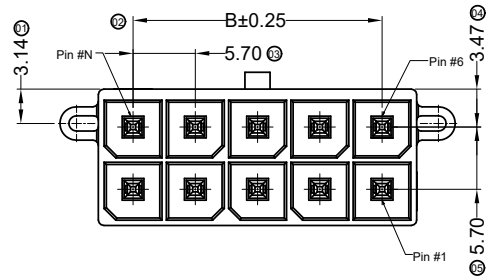

**Specifications :**

- Voltage rating: 600V AC / DC
- Current rating: 23A AC / DC
- Withstanding voltage: 2200V AC/minute
- Temperature range: -40°C~+105°C
- Insulation resistance: ≥1000MΩ
- Contact resistance: ≤2mΩ
- After environmental testing: ≤10mΩ
- Mates With GYA Housing: 5700H

5700 W V X-2\*XX X -LP SW BK T

① ② ③ ④ ⑤ ⑥ ⑦ ⑧ ⑨ ⑩

- ① Series No.
- ② Category: W-WAFER
- ③ Welding Board Angle: V-Straight 180°
- ④ Welding Way: Blank-DIP
- ⑤ Row No.-Pin No.: 2\*XX-2\*02P~2\*06P
- ⑥ Plug the Pin & Special No.: H-High conductive Brass
- ⑦ Material: LP -LCP 94V-0
- ⑧ Plating Category: SW-Matte Tin Plating
- ⑨ Color : Bk-Black
- ⑩ Packing Form: T-Tray

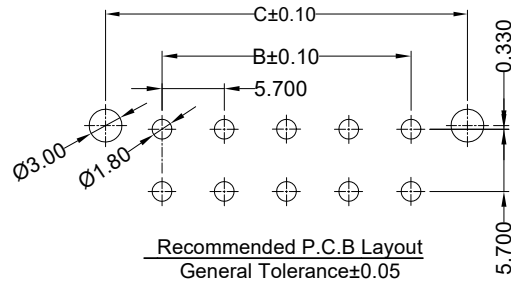
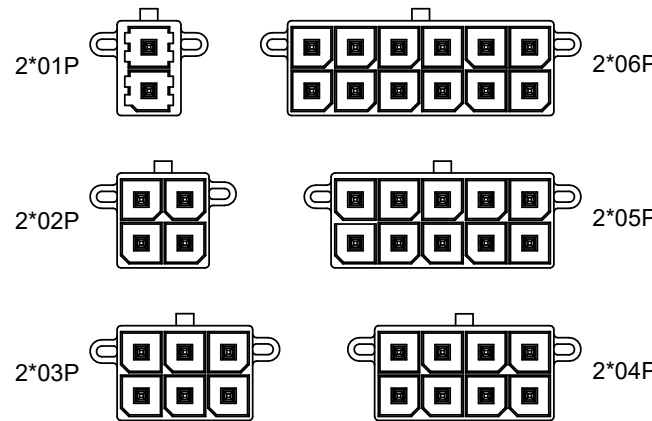
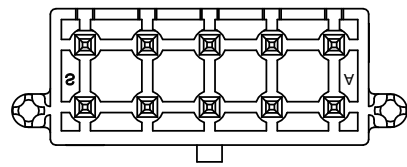

Poles	Dimensions (mm)		
	A	B	C
2*01	8.35	5.70	12.34
2*02	12.05	5.70	16.04
2*03	17.75	11.40	21.74
2*04	23.45	17.10	27.44
2*05	29.15	22.80	33.14
2*06	34.85	28.50	38.84

					GENERAL TOLERANCE		<b>东莞市国亚电子有限公司</b> DONGGUO GUOYA ELECTRONICS CO.,LTD				PART NO.				
					.X ±0.30						5700WV-2*XXH-LPSWBKT				
					.XX ±0.20		APPROVAL				TITLE				
					.XXX ±0.10						5.70 mm Crimp Style Connectors				
					X.° ±2°		YANG				UNIT				
DATE					PROJECT						TIAN				SCALE
REV					①		TIAN								SHEET
ECN ON.					②						TIAN				REV
DESCRIPTION					③		2017/02/25								NUMBER
MODIFY					④										mm
APPROVAL					⑤										1:1
					⑥										1/1
					⑦										A0
					⑧										A-000

RoHS

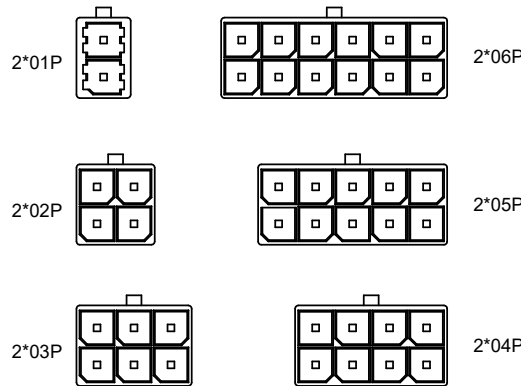
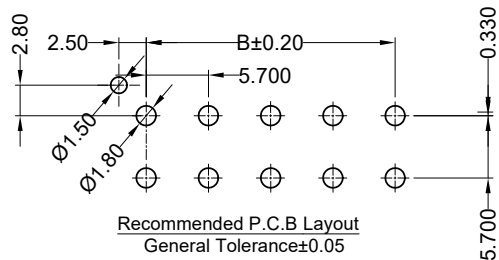
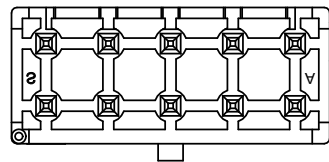
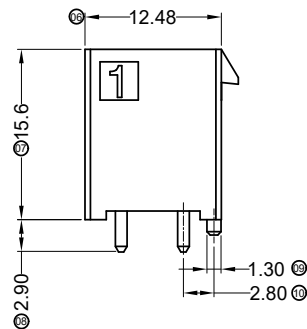
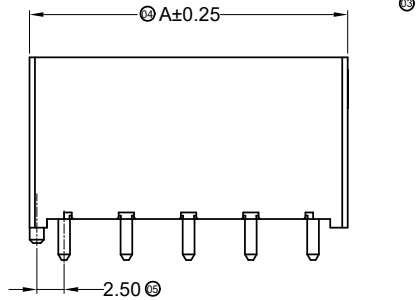
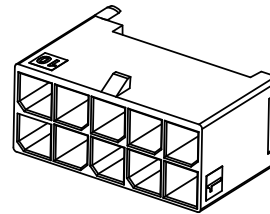
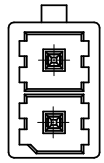
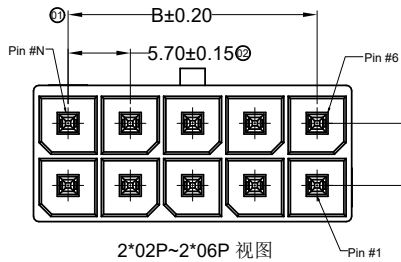

2\*01P~2\*06P 视图

■ Specifications :

- Voltage rating: 600V AC / DC
- Current rating: 23A AC / DC
- Withstanding voltage: 2200V AC/minute
- Temperature range:-40°C~+105°C
- Insulation resistance:≥1000MΩ
- Contact resistance: ≤2mΩ
- After environmental testing: ≤10mΩ
- Mates With GYA Housing:5700H-2\*XX

5700 WV - 2 x XX-LP B H 05 B H 001 F

① ② ③ ④ ⑤ ⑥ ⑦ ⑧ ⑨ ⑩ ⑪ ⑫

- ① Series No.
- ② Category: W-wafer
- ③ Connector Type: V- 180°
- ④ Bay Number: 2-Double Row
- ⑤ Row No.-Pin No: XX (2x2=4P... ..)
- ⑥ Plastic Material: LP-LCP 94V-0 ;
- ⑦ Color: B-BLACK
- ⑧ Hardware Material: H-High conductivity copper
- ⑨ Planting Code: 05-Matte tin plating
- ⑩ Packing: B-Bag
- ⑪ ROHS/HF: H-Halogen Free
- ⑫ Sequence Number: 001-Left single positioning column

Poles	Dimensions (mm)		
	A	B	C
2*01	8.35	/	12.34
2*02	12.05	5.70	16.04
2*03	17.75	11.40	21.74
2*04	23.45	17.10	27.44
2*05	29.15	22.80	33.14
2*06	34.85	28.50	38.84

					GENERAL TOLERANCE		<b>东莞市国亚电子有限公司</b> DONGGUO GUOYA ELECTRONICS CO.,LTD				PART NO. 5700WV-2xXX-LPBH05BH001F					
					.X ±0.30						TITLE 5.70 mm Crimp Style Connectors					
					.XX ±0.20		APPROVAL		CHECK	DRAWN						DATE
					.XXX ±0.10		YANG		TIAN	TIAN	2019/04/04	mm	1:1	1/1	A0	A-000
					X.° ±2°		PROJECT									
DATE	REV	ECN NO	DESCRIPTION	MODIFY	APPROVAL											

RoHS

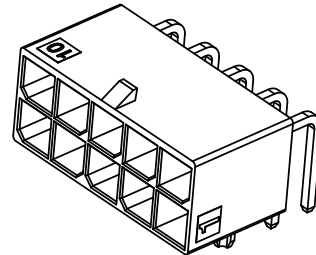
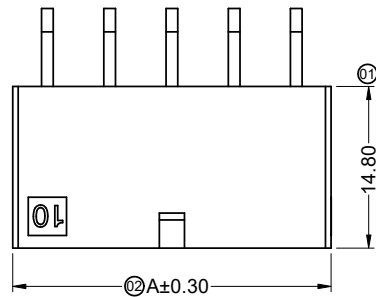

Poles	Dimensions (mm)	
	A	B
2*01	8.35	
2*02	12.05	5.70
2*03	17.75	11.40
2*04	23.45	17.10
2*05	29.15	22.80
2*06	34.85	28.50

Specifications :

- Voltage rating: 600V AC / DC
- Current rating: 23A AC / DC
- Withstanding voltage: 2200V AC/minute
- Temperature range: -40°C~+105°C
- Insulation resistance: ≥1000MΩ
- Contact resistance: ≤2mΩ
- After environmental testing: ≤10mΩ
- Mates With GYA Housing: 5700H

5700 W R X-2\*XX X -LP SW BK X

① ② ③ ④ ⑤ ⑥ ⑦ ⑧ ⑨ ⑩

- ① Series No.
- ② Category: W-WAFER
- ③ Connector Type: R-Straight 90°
- ④ Mounting Type: Blank-DIP
- ⑤ Row No.-Pin No Per Row: 2\*XX-2\*02P~2\*06P
- ⑥ Special No.: H-High conductive Brass
- ⑦ Material: LP -LCP 94V-0
- ⑧ Plating Code: SW-Matte Tin Plating
- ⑨ Color : BK-Black Color
- ⑩ Packing : T-Tray ; R-Reel

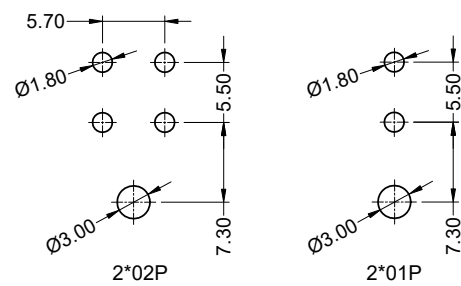
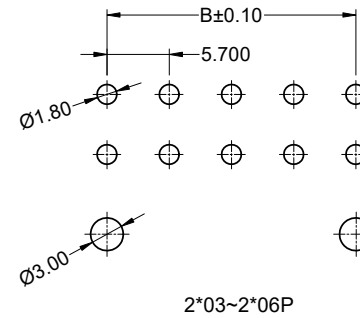
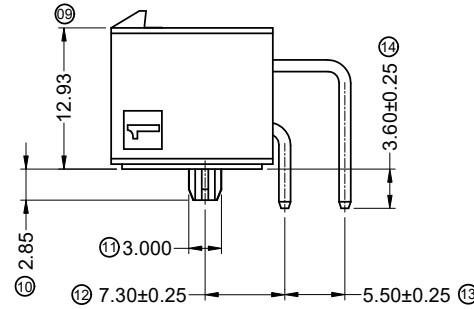
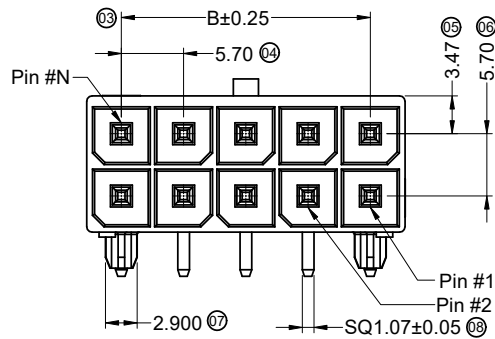

Recommended P.C.B Layout  
General Tolerance±0.05

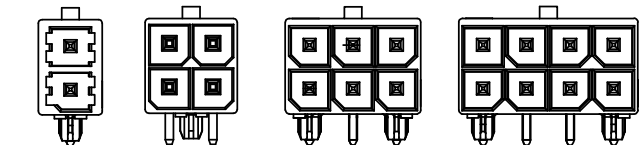

2 Circuit 4 Circuit 6 Circuit 8 Circuit

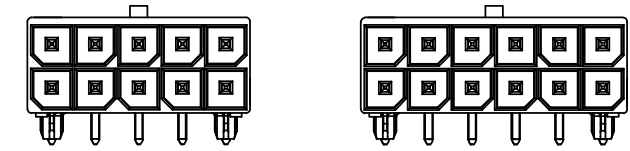

10 Circuit 12 Circuit

					GENERAL TOLERANCE				东莞市国亚电子有限公司 DONGGUO GUOYA ELECTRONICS CO.,LTD				PART NO.				
					.X ±0.30								5700WR-2*XXH-LPSWBKT				
					.XX ±0.20				APPROVAL				TITLE				
					.XXX ±0.10								5.70 mm Crimp Style Connectors				
					X.° ±2°				CHECK				UNIT				
					PROJECT				DRAWN				SCALE				
DATE					REV				DATE				SHEET				
ECN NO					APPROVAL				TIAN				REV				
DESCRIPTION					YANG				TIAN				NUMBER				
MODIFY					PROJECT				2017/02/25				mm				
					①								1:1				
													1/1				
													A0				
													A-000				