

RoHS

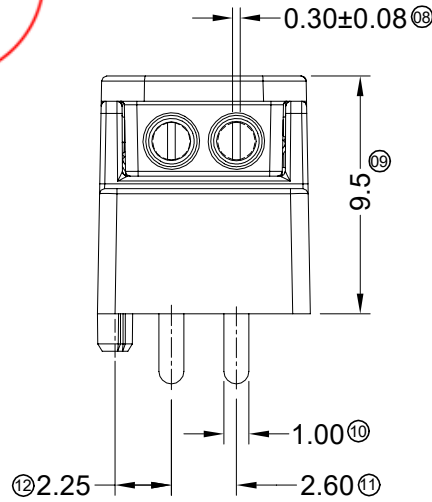
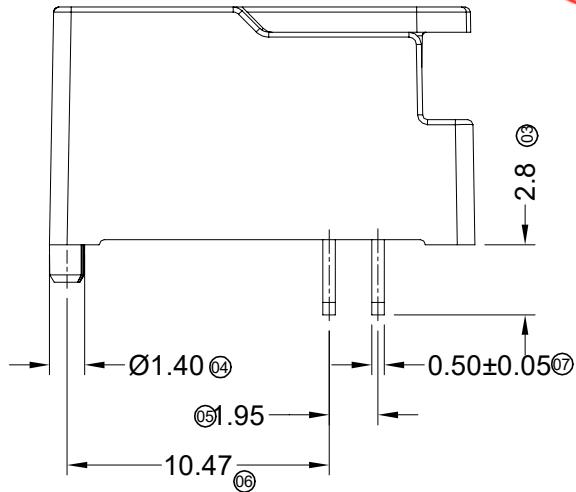
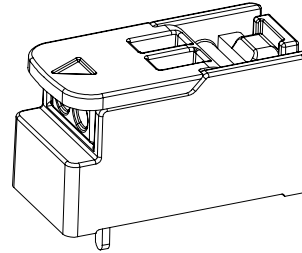
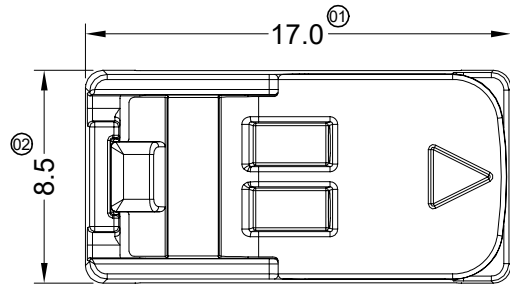

■ Specifications :

- Voltage rating: 100V AC / DC
- Current rating: 2.0A AC / DC
- Withstanding voltage: 500V AC/minute
- Temperature range: -25°C~+85°C
- Insulation resistance: ≥500MΩ
- Terminal resistance: ≤4mΩ

■ Material:

- Housing&Cover : ABS+PC, UL94V-0 HF
Colour ;White(RAL 9010)
- Terminal: Phosphor bronze
Plating : 100u" Sn Over 50u" Ni
- Contact Retention :15 N Min

2600 W V X - 02 HF - AP SN1 WH T

① ② ③ ④ ⑤ ⑥ ⑦ ⑧ ⑨ ⑩

- ① Series No.
- ② Category: W-wafer
- ③ Welding Board Angle: V- Straight 180°
- ④ Welding Way: Blank-DIP
- ⑤ Row No.-Pin No.: 02-02P
- ⑥ Plug the Pin & Special No.: HF-Halogen Free
- ⑦ Material: AP-ABS+PC UL94V-0
- ⑧ Planting Category: SN1-Tin plating
- ⑨ Color: WH-White
- ⑩ Packing Form: T-Tray

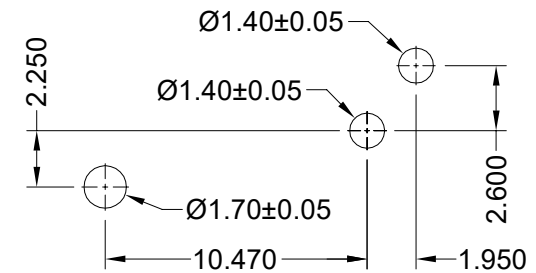

P.C.B LAYOUT

					<p>GENERAL TOLERANCE</p> <p>.X ±0.30</p> <p>.XX ±0.20</p> <p>.XXX ±0.10</p> <p>X.° ±2°</p>				<p>GYA 东莞市国亚电子有限公司 DONGGUO GUOYA ELECTRONICS CO.,LTD</p>				<p>PART NO. 2600WV-02HF-APSN1WHT</p>				
					<p>PROJECT</p> <p>YANG</p>				<p>APPROVAL</p> <p>YANG</p>				<p>CHECK</p> <p>TIAN</p>				
					<p>DATE</p> <p>2017/06/12</p>				<p>DRAWN</p> <p>TIAN</p>				<p>DATE</p> <p>2017/06/12</p>				
DATE					DESCRIPTION					TITLE							
REV					MODIFY					UNIT							
ECN NO					APPROVAL					SCALE							
										SHEET							
										REV							
										NUMBER							
										mm							
										1:1							
										1/1							
										A0							
										A-000							