

RoHS

包装图

Note 注解:

- Put Housing in a PE bag, PE bag gauge for: 130 * 135 * 0.10 mm, Packing detail see the table below
将 Housing 放入PE袋内, PE袋规为: 130*135*0.10mm, 详细包装见下表
- Put PE bag packed products in specifications of 380 * 310 * 450 mm cartons, Packing detail see the table below
将装好产品的PE袋放入规格为380 * 310 * 450mm 的纸箱内, 详细包装见下表
- Label depends on customer request, carton opening joint with transparent tape
标签依客户要求而定, 纸箱开口处用透明胶带贴合.
- Carton material : K=K, Carton thickness : 6±1mm
纸箱材质: K=K, 纸箱厚度: 6±1mm

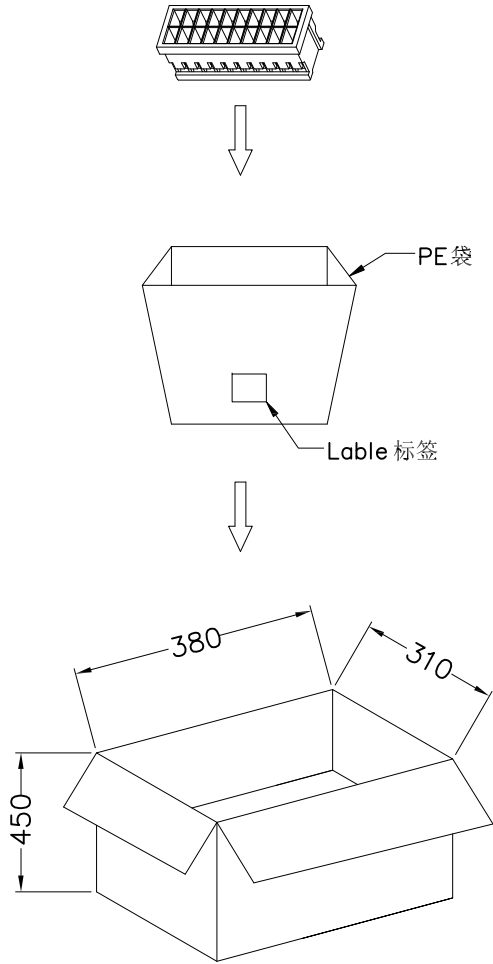

Poles	Bag PCS	CARTON Bag	CARTON PCS
2*10	1000	50	50K

胶带ADHESIVE TAPE

标签 LABEL



DATE	REV	ECN NO.	DESCRIPTION	MODIFY	APPROVAL	GENERAL TOLERANCE	APPROVAL				PART NO.:			
						.X ±0.30	GYA 东莞市国亚电子有限公司 Dong Guan Guo Ya Connectors co.,ltd	CHECK	DRAWN	DATE	1511H-2*10-PTXX			
					.XX ±0.20	TITLE:								
					.XXX ±0.10	1.50mm Housing Packing								
					X' ±0.2°	UNIT					SCALE	SHEET	REV	NUMBER
					视角	Yangzhengguo	Yangzhengyi	Lvtiansheng	2016/08/26	mm	1:1	1/1	A0	A-241

RoHS

包装图

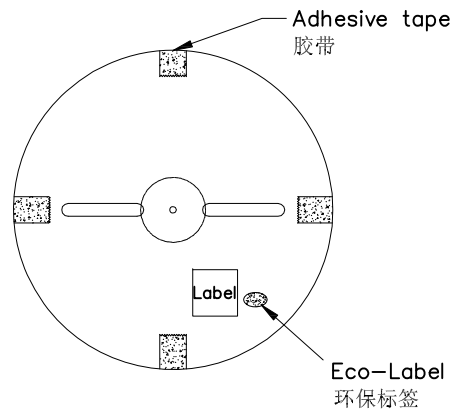

Note 注解:

- Quantity 数量:
10KPCS/REEL 一卷10K/PCS
10REEL/BOX 一箱10卷
100KPCS/BOX 一箱100K/PCS
- Each reel and outer box must be labeled and Eco-Label Respectively labeled
每盘和外箱都必须有标签及环保标签分别标示
- Terminal winding direction as shown
端子缠绕方向如左图所示
- There shall be no dirt such as deformation phenomenon, Mantissa box fillers must be used
每箱不可有脏污, 变形现象, 尾数箱必须用填充物
- Carton material : K=K, Carton thickness : 6±1mm
纸箱材质: K=K 纸箱厚度: 6±1mm

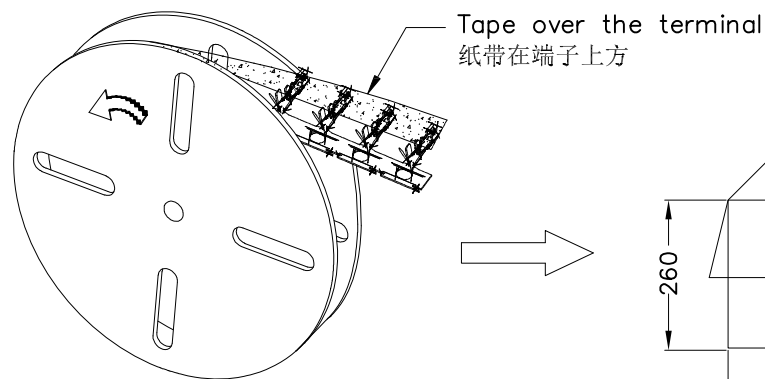

卷装方式
Package way

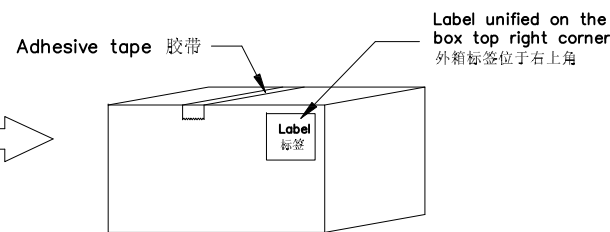
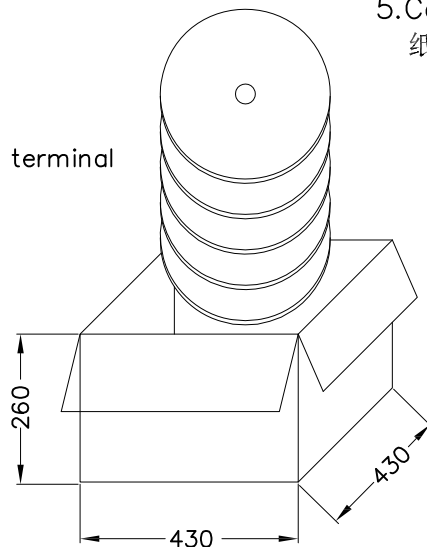

				GENERAL TOLERANCE		GYA 东莞市国亚电子有限公司 Connectors Dong Guan Guo Ya Connectors co., ltd		PART NO.: 1511T-XXX-XX	
				.X ±0.30		APPROVAL		TITLE: 1.50mm Terminal Packing	
				.XX ±0.20		CHECK		UNIT	
				.XXX ±0.10		DRAWN		SCALE	
				X' ±0.2°		DATE		SHEET	
DATE	REV	ECN NO.	DESCRIPTION	MODIFY	APPROVAL	Yangzhengguo	Yangzhengyi	Lvtiansheng	2016/08/26
				视角				REV	
				视				NUMBER	
				角				mm	
				图				1:1	
								1/1	
								A0	
								A-014	

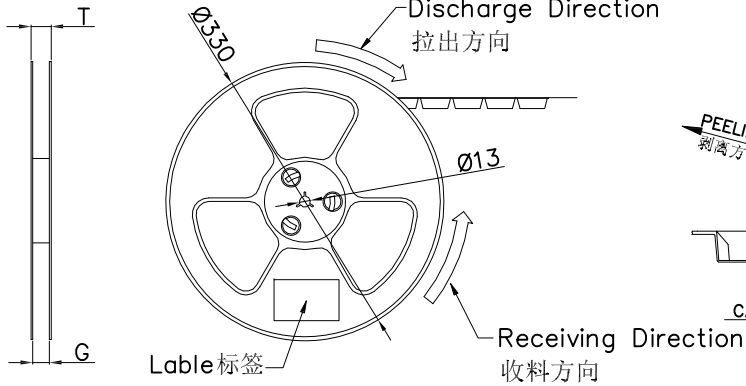
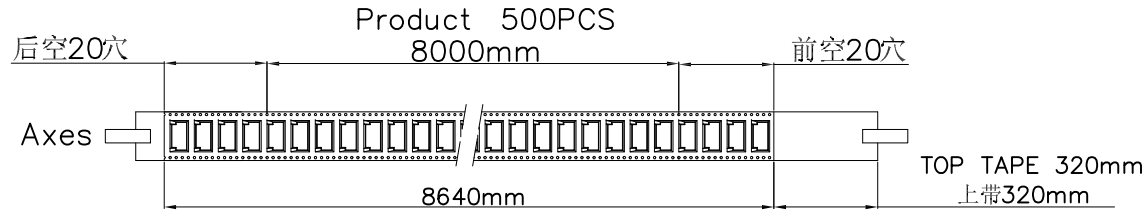

Single hole: None Hole Side
 单孔: 贴无锯齿侧
 Double hole: Elliptical Hole Side
 双孔: 贴椭圆孔侧

COVER TAPE PEEL STRENGTH: 20~120g
 上带剥离力量: 20~120g
 速度 PEEL SPEED: 300mm/minute

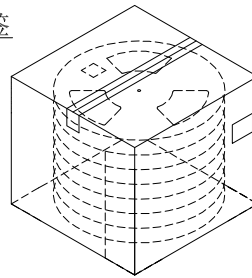
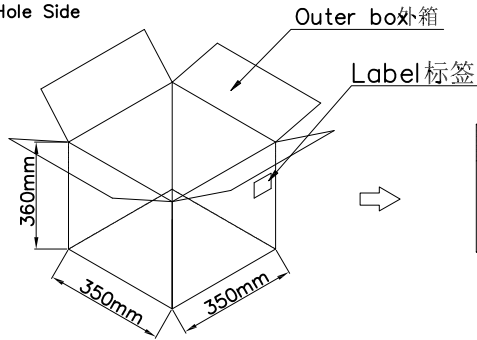
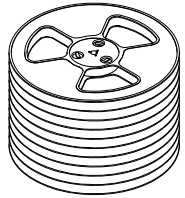
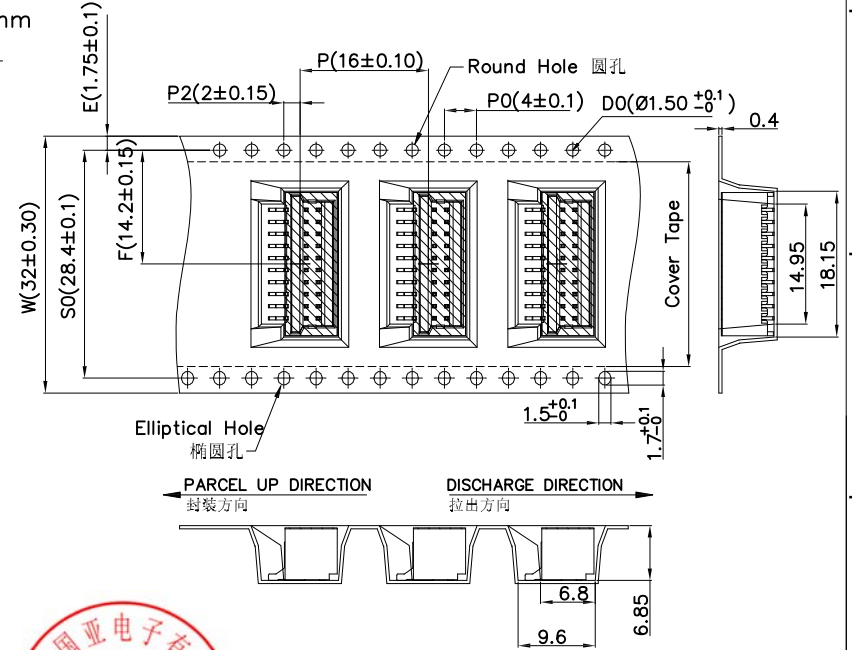
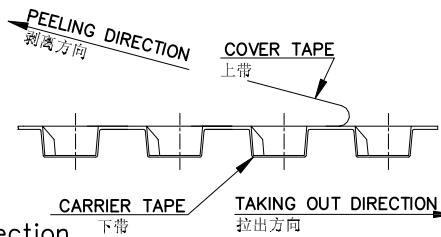

- Note:
- Carrier Camber Is Within 1mm In 100mm ; 带长100mm 内容许弯曲度1mm
 - 10 Sprocket Hole Pitch Cumulative Tolerance±0.2MM ; 圆孔十个孔距离累计允许公差为±0.2mm
 - Carrier tape material for PS ; 下带材质为PS材质; Color 颜色: Natural 透明无色无卤
 - Thickness=0.40±0.05 ; 材料厚度为0.40±0.05mm
 - Carton material 纸箱材质:K=K; Carton Thickness 纸箱厚度: 6±1mm

ZD1511WVS-2*10HF 1511WVS-2*10HX-XXXX	Pin No.	W	S	F	T	G	REEL /PCS	CARTON /R	CARTON /PCS
	ZD1511WVS-2*10HF	32	28.40	14.20	36.50	32.40	500	9R	4500

					GENERAL TOLERANCE		GYA 东莞市国亚电子有限公司 Dong Guan Guo Ya Connectors co., Ltd APPROVAL CHECK DRAWN DATE Yangzhengguo Yangzhengyi Lviansheng 2016/08/26			PART NO.: PPN: 1511WVS-2*10HX-XXXX CTN: ZD1511WVS-2*10HF				
					.X ±0.30					TITLE: 1.50mm SMT 180° Packing				
					.XX ±0.20					UNIT SCALE SHEET REV NUMBER				
					.XXX ±0.10					mm 1:1 1/1 A0 A-000				
DATE	REV	ECN NO.	DESCRIPTION	MODIFY	APPROVAL	视角								

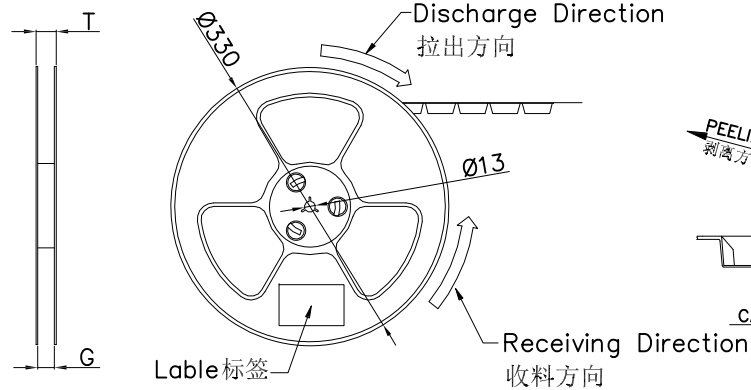
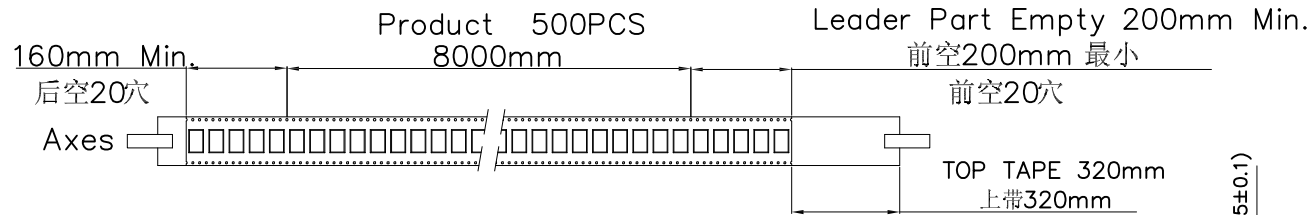

Lable 标签
 Single hole: None Hole Side
 单孔: 贴无锯齿侧
 Double hole: Elliptical Hole Side
 双孔: 贴椭圆孔侧

COVER TAPE PEEL STRENGTH: 20~120g
 上带剥离力量: 20~120g
 速度 PEEL SPEED: 300mm/minute

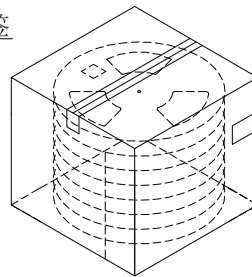
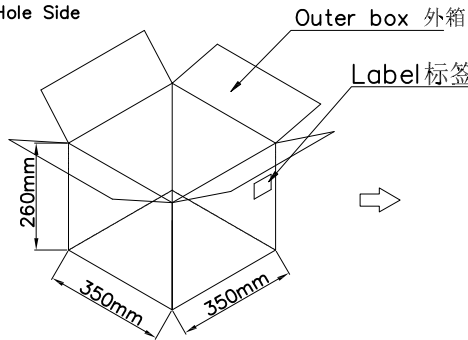
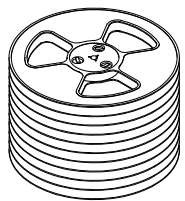
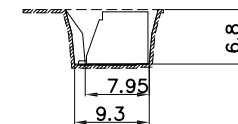
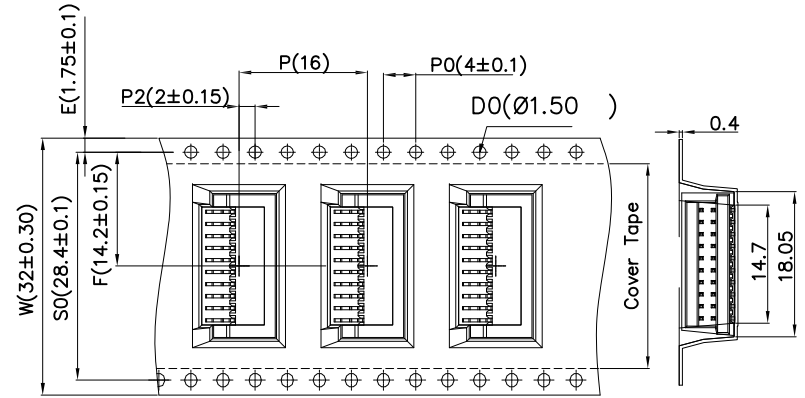
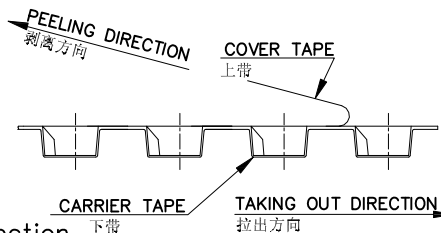

Note:

1. Carrier Camber Is Within 1mm In 100mm ; 带长100mm 内容许弯曲度1mm
2. 10 Sprocket Hole Pitch Cumulative Tolerance±0.2MM ; 圆孔十个孔距离累计允许公差为±0.2mm
3. Carrier tape material for PS ; 下带材质为PS材质; Color 颜色: Natural 透明色
4. Thickness=0.40±0.05 ; 材料厚度为0.40±0.05mm
5. Carton material 纸箱材质: K=K; Carton Thickness 纸箱厚度: 6±1mm

ZD1511WRS-2*10HF 1511WRS-2*10HX-LPV01	Pin No.	W	S	F	T	G	REEL /PCS	CARTON /R	CARTON /PCS
	ZD1511WRS-2*10HF	32	28.40	14.20	36.50	32.40	500	6R	3000

						GENERAL TOLERANCE		东莞市国亚电子有限公司 Dong Guan Guo Ya Connectors co., ltd.		PART NO.: PPN: 1511WRS-2*10HX-LPXX CTN: ZD1511WRS-2*10HF				
						.X ±0.30				TITLE: 1.50mm SMT 90° Packing				
						.XX ±0.20				APPROVAL		CHECK	DRAWN	DATE
						.XXX ±0.10				Yangzhengguo		Yangzhengyi	Lvtiansheng	2016/08/26
						X' ±0.2°		UNIT		SCALE	SHEET	REV	NUMBER	
DATE	REV	ECN NO.	DESCRIPTION	MODIFY	APPROVAL	视角		mm		1:1	1/1	A0	A-106	